

Compliance Guide

2015 NFPA 101 LIFE SAFETY CODE 7.2.2.5.5 EXIT STAIR PATH MARKINGS

7.2.2.5.5 Exit Stair Path Markings

Where exit stair path markings are required in Chapters 11 through 43, such markings shall be installed in accordance with 7.2.2.5.5.1 through 7.2.2.5.5.11.

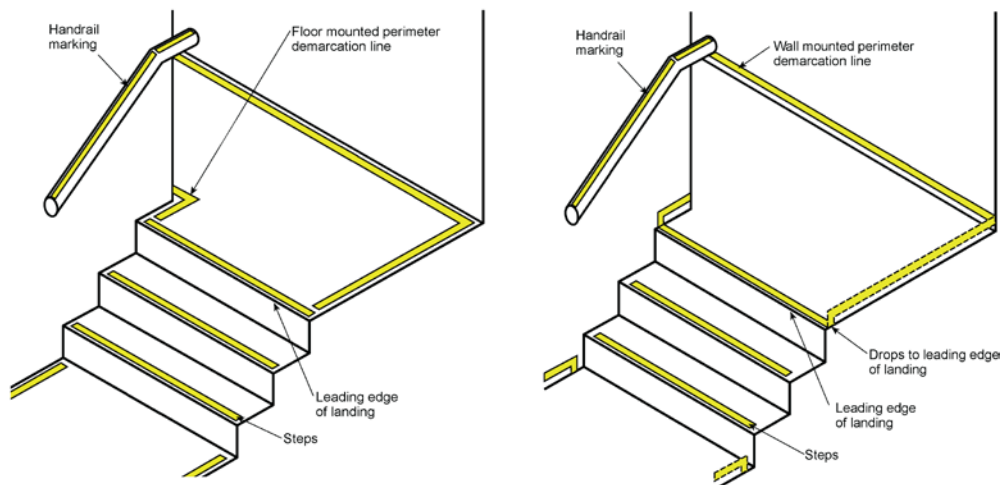

7.2.2.5.5.1 Exit Stair Treads

Exit stair treads shall incorporate a marking stripe that is applied as a paint/coating or be a material that is integral with the nosing of each step.

- (A) The marking stripe shall be installed along the horizontal leading edge of the step and shall extend the full width of the step.
- (B) The marking stripe shall also meet all of the following requirements:
 - (1) The marking stripe shall be not more than ½ in. (13 mm) from the leading edge of each step and shall not overlap the leading edge of the step by more than ½ in. (13 mm) down the vertical face of the step.
 - (2) The marking stripe shall have a minimum horizontal width of 1 in. (25 mm) and a maximum width of 2 in. (51 mm).
 - (3) The dimensions and placement of the marking stripe shall be uniform and consistent on each step throughout the exit enclosure.
 - (4) Surface-applied marking stripes using adhesive-backed tapes shall not be used.

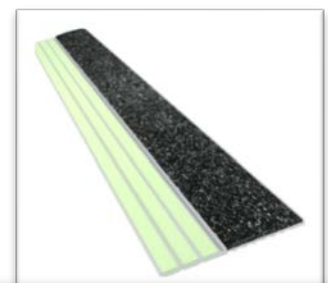

CLICK HERE
To View Code Compliant Ecoglo
Step Edge Products

7.2.2.5.5.2 Exit Stair Landings

The leading edge of exit stair landings shall be marked with a solid and continuous marking stripe consistent with the dimensional requirements for stair treads and shall be the same length as, and consistent with, the stripes on the steps.

7.2.2.5.5.3 Exit Stair Handrails

All handrails and handrail extensions shall be marked with a solid and continuous marking stripe and meet all of the following requirements:

- (1) The marking stripe shall be applied to the upper surface of the handrail or be a material integral with the upper surface of the handrail for the entire length of the handrail, including extensions.
- (2) Where handrails or handrail extensions bend or turn corners, the marking stripe shall be permitted to have a gap of not more than 4 in. (100 mm).
- (3) The marking stripe shall have a minimum horizontal width of 1 in. (25 mm), which shall not apply to outlining stripes listed in accordance with ANSI/UL 1994, *Standard for Luminous Egress Path Marking Systems*.
- (4) The dimensions and placement of the marking stripe shall be uniform and consistent on each handrail throughout the exit enclosure.

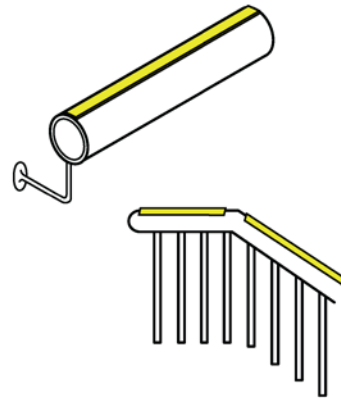

CLICK HERE
To View Code Compliant Ecoglo
Handrail Marking Products

7.2.2.5.5.4 Perimeter Demarcation Marking

Stair landings, exit passageways, and other parts of the floor areas within the exit enclosure shall be provided with a solid and continuous perimeter demarcation marking stripe on the floor or on the walls or a combination of both. The marking stripe shall also meet all of the following requirements:

- (1) The marking stripe shall have a minimum horizontal width of 1 in. (25 mm) and a maximum width of 2 in. (51 mm), with interruptions not exceeding 4 in. (100 mm).
- (2) The minimum marking stripe width of 1 in. (25 mm) shall not apply to outlining stripes listed in accordance with ANSI/UL 1994, *Standard for Luminous Egress Path Marking Systems*.
- (3) The dimensions and placement of the perimeter demarcation marking stripe shall be uniform and consistent throughout the exit enclosure.
- (4) Surface-applied marking stripes using adhesive-backed tapes shall not be used.

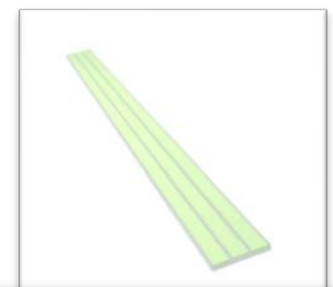

CLICK HERE
To View Code Compliant Ecoglo
Perimeter Marking Products

(A) Perimeter floor demarcation lines shall comply with all of the following:

- (1) They shall be placed within 4 in. (100 mm) of the wall and extend to within 2 in. (51 mm) of the markings on the leading edge of landings.
- (2) They shall continue across the floor in front of all doors.
- (3) They shall not extend in front of exit doors leading out of an exit enclosure and through which occupants must travel to complete the egress path.

(B) Perimeter wall demarcation lines shall comply with all of the following:

- (1) They shall be placed on the wall with the bottom edge of the stripe not more than 4 in. (100 mm) above the finished floor.
- (2) At the top or bottom of the stairs, they shall drop vertically to the floor within 2 in. (51 mm) of the step or landing edge.
- (3) They shall transition vertically to the floor and then extend across the floor where a line on the floor is the only practical method of outlining the path.
- (4) Where the wall line is broken by a door, they shall continue across the face of the door or transition to the floor and extend across the floor in front of such door.
- (5) They shall not extend in front of doors leading out of an exit enclosure and through which occupants must travel to complete the egress path.
- (6) Where a wall-mounted demarcation line transitions to a floor-mounted demarcation line, or vice versa, the wall-mounted demarcation line shall drop vertically to the floor to meet a complementary extension of the floor-mounted demarcation line, thus forming a continuous marking.

7.2.2.5.5.5 Obstacles

Obstacles that are in the exit enclosure at or below 6 ft 6 in. (1980 mm) in height, and that project more than 4 in. (100 mm) into the egress path, shall be identified with markings not less than 1 in. (25 mm) in horizontal width comprised of a pattern of alternating equal bands of luminescent material and black; and with the alternating bands not more than 2 in. (51 mm) in horizontal width and angled at 45 degrees.



CLICK HERE
To View Code Compliant Ecoglo
Obstruction Marking Products

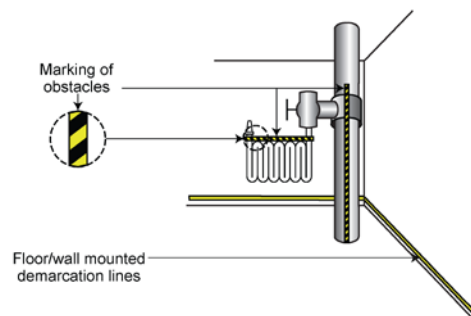

7.2.2.5.5.6 Doors Serving Exit Enclosure

All doors serving the exit enclosure that swing out from the enclosure in the direction of egress travel shall be provided with a marking stripe on the top and sides of the door(s) frame(s). The marking stripe shall also meet all of the following requirements:

- (1) The marking stripe shall have a minimum horizontal width of 1 in. (25 mm) and a maximum width of 2 in. (51 mm).
- (2) Gaps shall be permitted in the continuity of door frame markings where a line is fitted into a corner or bend, but shall be as small as practicable, and in no case shall gaps be greater than 1 in. (25 mm).
- (3) Where the door molding does not provide enough flat surface on which to locate the marking stripe, the marking stripe shall be located on the wall surrounding the frame.
- (4) The dimensions and placement of the marking stripe shall be uniform and consistent on all doors in the exit enclosure.

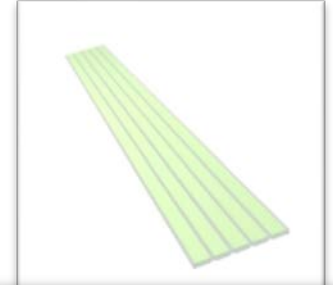

CLICK HERE
To View Code Compliant Ecoglo
Door Frame Marking Products

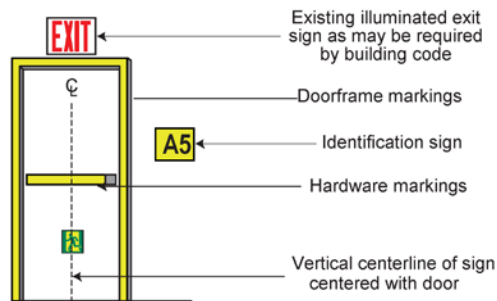

7.2.2.5.5.7 Door Hardware Marking

- (A) The door hardware for the doors serving the exit enclosure that swing out from the enclosure in the direction of egress travel shall be provided with a marking stripe.
- (B) The marking stripe shall also meet the following requirements:
 - (1) The door hardware necessary to release the latch shall be outlined with an approved marking stripe having a minimum width of 1 in. (25 mm).
 - (2) Where panic hardware is installed, both of the following criteria shall be met:
 - (a) The marking stripe shall have a minimum horizontal width of 1 in. (25 mm) and be applied to the entire length of the actuating bar or touch pad.
 - (b) The placement of the marking stripe shall not interfere with viewing of any instructions on the actuating bar or touch pad.



CLICK HERE
To View Code Compliant Ecoglo
Door Hardware Marking Products

7.2.2.5.5.8 Emergency Exit Symbol



An emergency exit symbol with a luminescent background shall be applied on all doors serving the exit enclosure that swing out from the enclosure in the direction of egress travel. The emergency exit symbol shall also meet both of the following requirements:

- (1) The emergency exit symbol shall meet the requirements of NFPA 170, *Standard for Fire Safety and Emergency Symbols*.
- (2) The emergency exit symbol applied on the door shall be a minimum of 4 in. (100 mm) in height and shall be applied on the door, centered horizontally, with the top of the symbol not higher than 18 in. (455 mm) above the finished floor.



CLICK HERE
To View Code Compliant Ecoglo
Directional Signage Products

7.2.2.5.5.9 Uniformity

Placement and dimensions of the marking stripes shall be consistent and uniform throughout the same exit enclosure.

7.2.2.5.5.10 Materials

Exit stair path markings shall be made of any material, including paint, provided that an electrical charge is not required to maintain the required luminescence. Such materials shall include, but shall not be limited to, self-luminous materials and photoluminescent materials. Materials shall comply with one of the following:

- (1) ASTM E 2072, *Standard Specification for Photoluminescent (Phosphorescent) Safety Markings*, with the following exceptions:
 - (a) The charging source shall be 1 ft-candle (10.8 lux) of fluorescent illumination for 60 minutes.
 - (b) The minimum luminance shall be 5 millicandelas/m² after 90 minutes.
- (2) ANSI/UL 1994, *Standard for Luminous Egress Path Marking Systems*



| |
|--|
| 7.2.2.5.5.10 Materials |
| All components UL 1994 listed and/or ASTM E 2072 compliant |

7.2.2.5.5.11 Exit Stair Illumination

Exit enclosures where photoluminescent materials are installed shall comply with all of the following:

- (1) The exit enclosure shall be continuously illuminated for at least 60 minutes prior to periods when the building is occupied.
- (2) The illumination shall remain on when the building is occupied.
- (3) Lighting control devices provided for illumination within the exit enclosure shall meet all of the following requirements:
 - (a) Lighting control devices that automatically turn exit enclosure lighting on and off, based on occupancy, shall be permitted, provided that they turn on illumination for charging photoluminescent materials for at least 60 minutes prior to periods when the building is occupied.
 - (b) Lighting used to charge photoluminescent materials shall not be controlled by motion sensors.
 - (c) Lighting control devices that dim the lighting levels within the exit enclosure shall not be installed unless they provide a minimum of 1 ft-candle (10.8 lux) of illumination within the exit enclosure measured at the walking surface.

COMPLIANCE QUICK REFERENCE

2012 NFPA 101 Life Safety Code 7.2.2.5.5 Exit Stair Path Markings

7.2.2.5.5.1 Exit Stair Treads - 7.2.2.5.5.2 Exit Stair Landings

- **E Series**
Photoluminescent contrast strips
- **F / RF Series**
Flat aluminum stair nosings with photoluminescent contrast strips
- **S Series**
Cast-in-place aluminum stair nosings with photoluminescent contrast strips
- **G3001 / G6001**
Photoluminescent guidance strip

7.2.2.5.5.3 Exit Stair Handrails

- **H Series**
Handrail strip and end caps
- **G3001 / G6001**
Photoluminescent guidance strip

7.2.2.5.5.4 Perimeter Demarcation Marking

- **T5-G3001 / T8-6001**
Aluminum track and photoluminescent guidance strip
- **G3001 / G6001**
Photoluminescent guidance strip

7.2.2.5.5.5 Obstacles

- **OB20025**
Photoluminescent obstruction strip
- **OB20025-TP**
Photoluminescent obstruction tape

7.2.2.5.5.6 Doors Serving Exit Enclosure

- **G6001**
Photoluminescent guidance strip

7.2.2.5.5.7 Door Hardware Marking

- **DHM Series**
Door hardware indicators

7.2.2.5.5.8 Emergency Exit Symbol

- **R Series**
Running man photoluminescent directional and door exit signs

7.2.2.5.5.10 Materials

All components UL 1994 listed and/or ASTM E 2072 compliant